



Vertical Blinds Installation Guide



We make it easy!

Before Starting

Your new Blinds To Go vertical blind is custom made to your specifications from the finest material available. Your installation should be easy and the blind will fit beautifully.

Mounting Options

Inside mount: Blind is mounted either into the ceiling or inside the window frame into the top of the frame.

Outside mount: Blind is mounted either on or outside the window frame.

Side mount: Blind is mounted to the two sides of the window frame.

Assembling The Valance

Important:

1. Assemble the valance **before** installing the blind, especially for an inside mount.
2. Refer to directions applicable to the type of valance specified in your order.
3. If you did not order a valance, proceed to page 5 "Installing your vertical blind".

Parts

Royal Valance

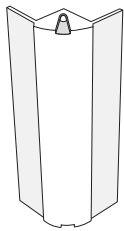

Corner Pieces
Quantity: 2

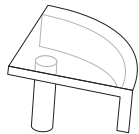

Corner Covers
Quantity: 4

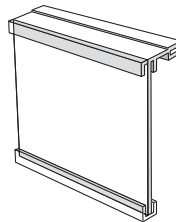

Valance Returns
Quantity: 2

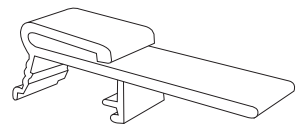

Valance Clips
Quantity: 2 or more depending on size of valance

Majestic Valance

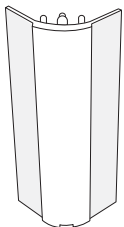

Corner Pieces
Quantity: 2, or 4 (for Double Majestic Valance)

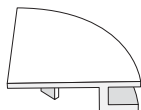

Corner Pieces
Quantity: 4, or 6 (for Double Majestic Valance)

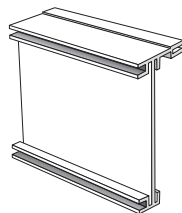

Valance Returns
Quantity: 2

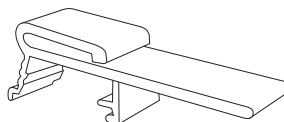

Valance Clips
Quantity: 2 or more (depending on size of valance)

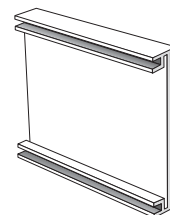

Lower Section Valance Returns
Quantity: 2

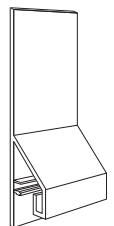

Lower Section Support Brackets
Quantity: 2 or more depending on size of valance

(only for Double Majestic Valance)

Step 1. Slide in valance insertion

Slide the valance insertion through the main valance section. **For a Double Majestic Valance, slide the valance insertion for both the main section and the lower section.**

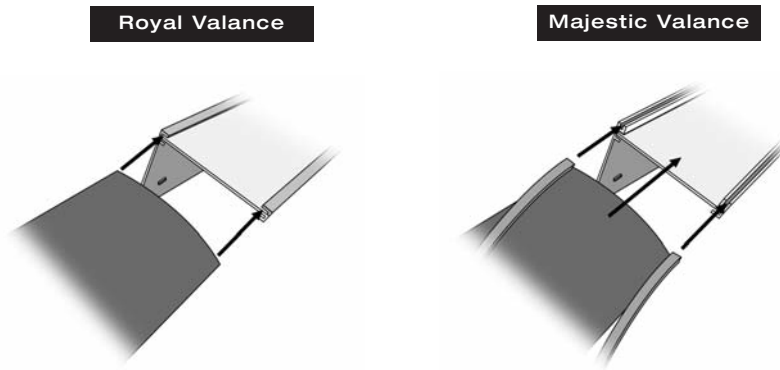

Note: If the material is too thick to slide in, pop the insertion into the main valance section. Take precaution not to break the material while bending the insertion.

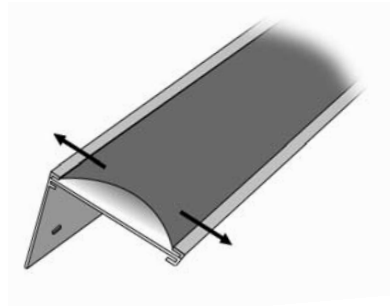

Step 2. Only for Double Majestic Valance: Attach the lower section

1. Slide all but two of the lower section support brackets into the main valance section (*Fig. A*) and space them evenly.
2. Attach the two sections by sliding the lower section through the lower section support brackets (*Fig. B*).

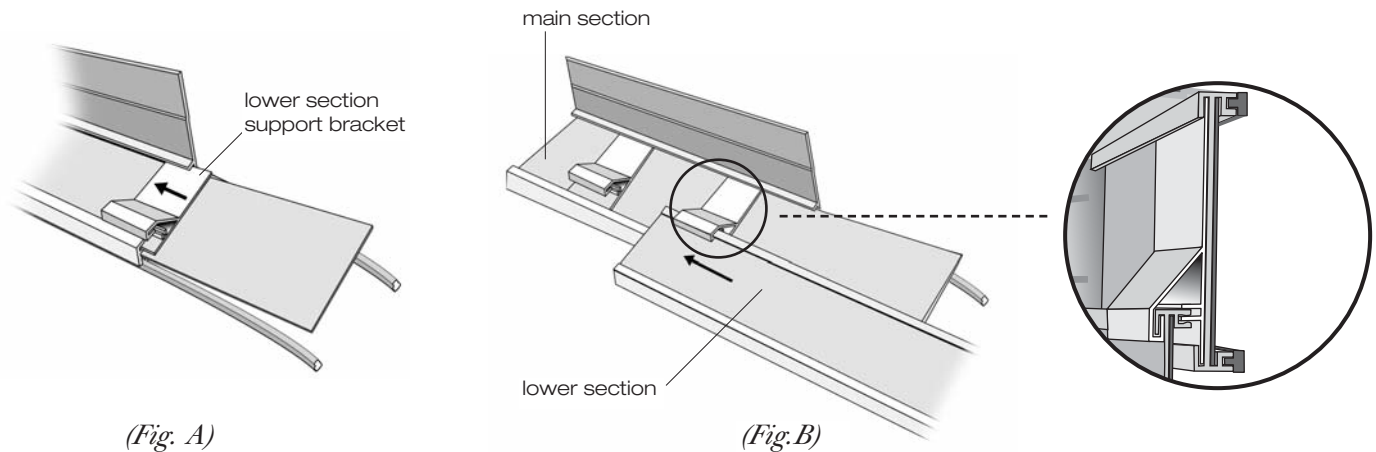

Step 3. Assemble the valance returns

Important for Double Majestic Valances: assemble the returns of the lower section **BEFORE** you assemble the returns of the main section.

1. Slide the corner pieces into the back slot of the main valance section.

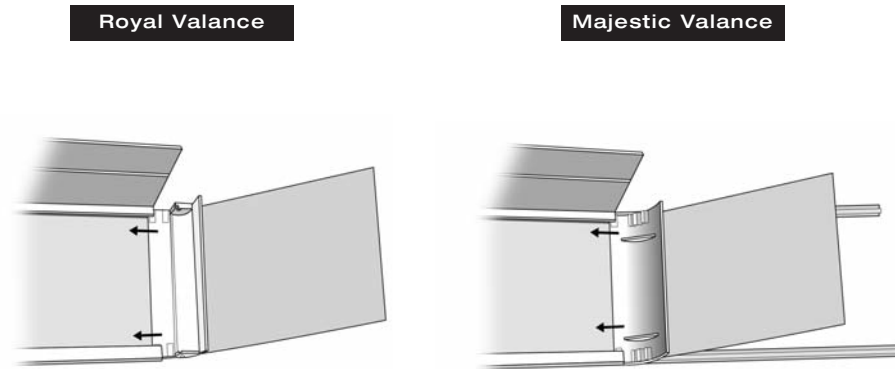

2. Insert the valance returns into the corner pieces.

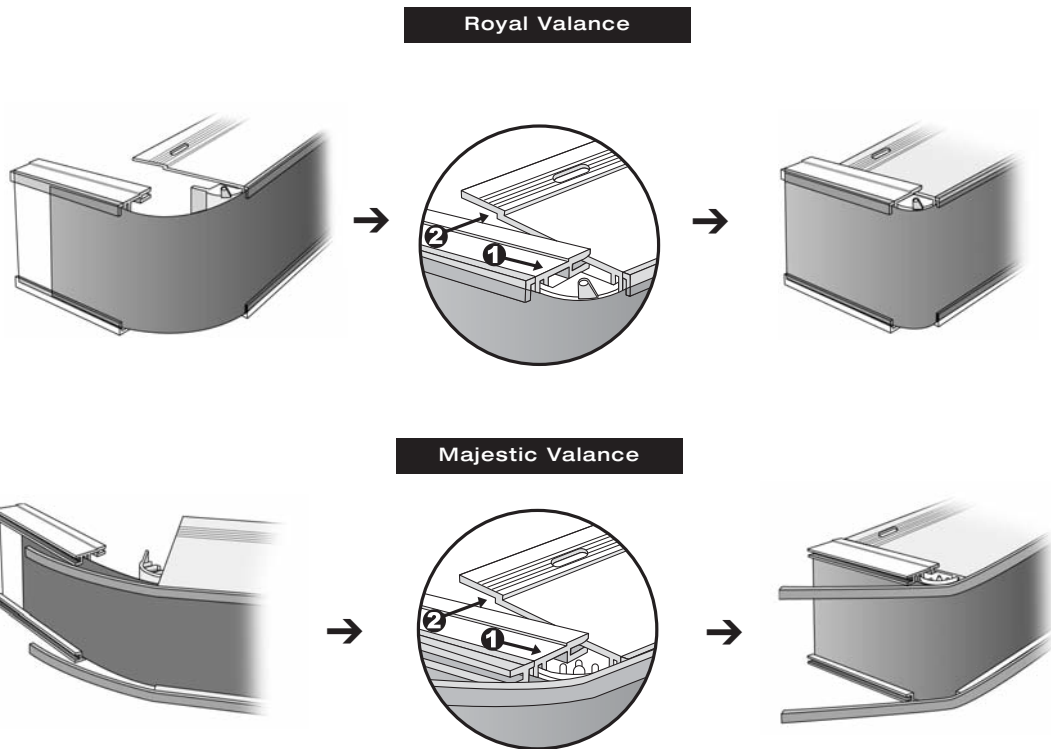

Note:

1. For **fabric valance insertion**, wrap the excess around the back of each return and hold the fabric insertion in place with household tape.
2. For **PVC or aluminum insertion**, trim off the excess with a utility knife by scoring the back of the insertion and snap it off.

3. Insert the four plastic top and bottom corners and push to secure entire valance.

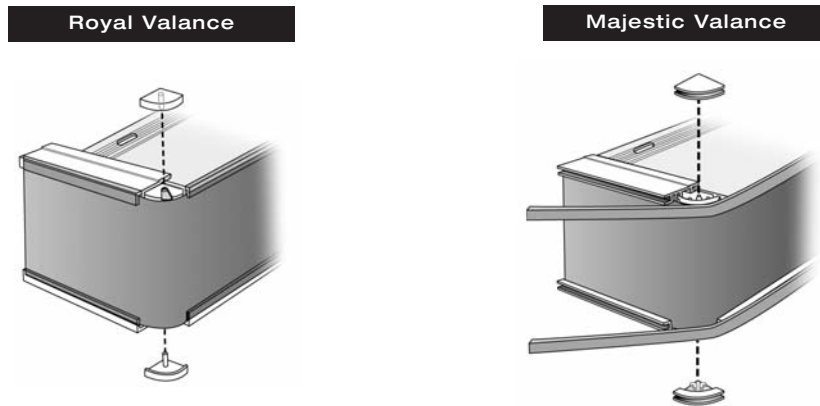

4. Only for Majestic valance: Secure the top and bottom colored trims by **pressing the trims into** the grooves of the corners and of the valance returns. Trim off any excess using ordinary scissors.

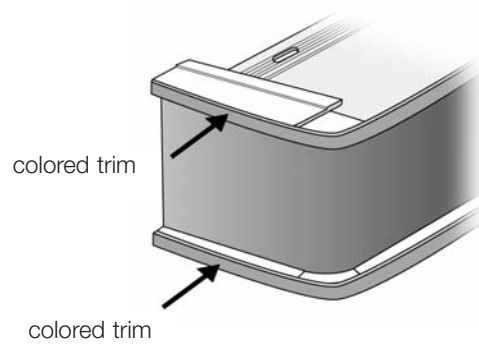

5. Only for Double Majestic Valance: Secure the returns of the lower section. **Slide** the two remaining lower section support brackets in position to secure the returns of the lower section.

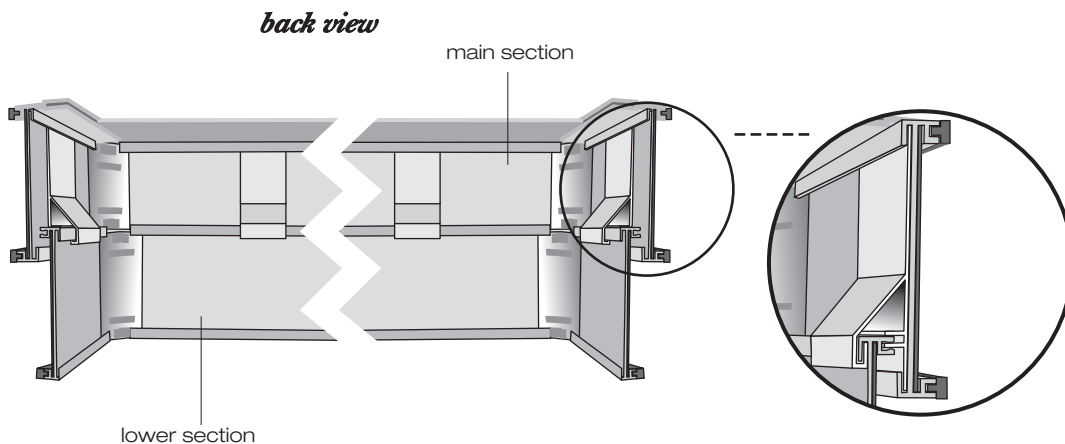

Installing Your Vertical Blind *(for most blinds, 2 people are required for the installation)*

(If you have ordered a valance for your blind, go to page 1 and assemble the valance before installing the blind.)

Parts

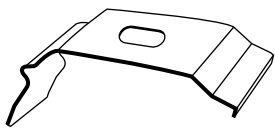

Mounting brackets
Quantity: 2 or more depending
on width of blind

or

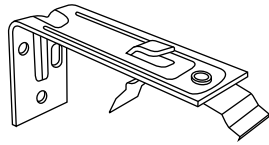

Mounting brackets
Quantity: 2 or more depending
on width of blind

or

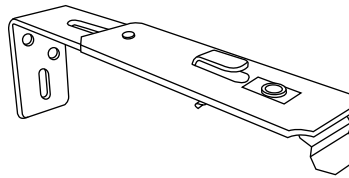

Mounting brackets
Quantity: 2 or more depending
on width of blind

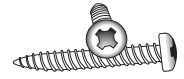

Mounting screws
Quantity: 2 per bracket

Note: Mounting screws provided are suitable for most mounting surfaces. See additional suggestions below.

For wallboard or plaster: Use hollow wall anchors for added support.

For concrete, stone, brick or tile: Use an appropriate drill bit and appropriate anchors before fastening the screws.

For metal surfaces: Pre-drill holes before fastening the screws.

Suggested Tools

- Drill
- Level
- Pencil
- Screwdriver
- Tape measure

Step 1. Mounting brackets

Inside Mount

Position the brackets on the mounting surface, approximately 6" in from each end of the track position, and at least 1" from the front of the frame and at least 1-3/4" from the back of the frame. Then mount with one screw per bracket (*Fig. A*).

Important: If you have ordered a valance (*Fig. B*),

1. Mount valance together with the brackets.
2. The bracket should be positioned so that the hole is **at least 2"** from the front of the frame and at least 1-3/4" from the back of the frame.
3. For the valance to be flush with the opening, the bracket screw should be positioned 2-1/4" from the front edge of the opening.

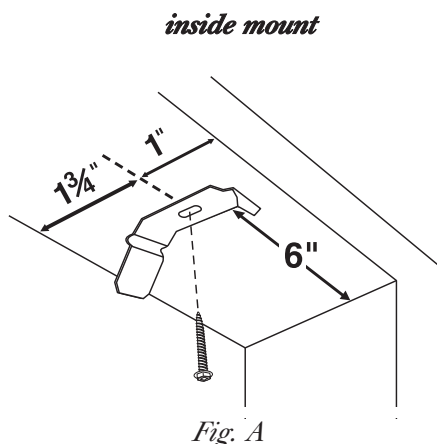

Fig. A

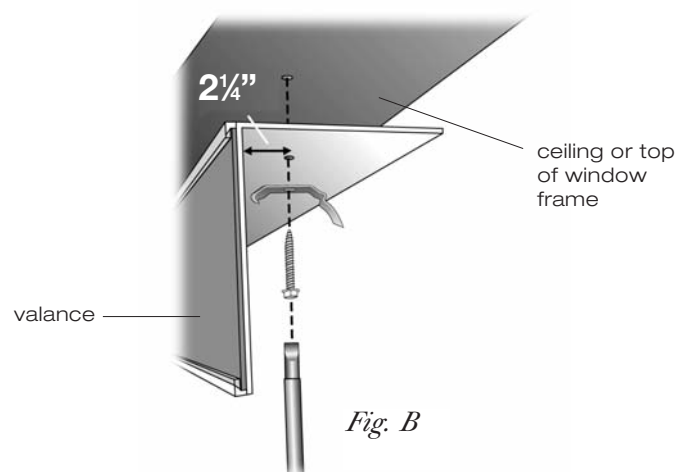

Fig. B

When more than two brackets are supplied, position the additional brackets evenly between the two end brackets.

Outside Mount and Side Mount

1. **First, mark the position of the track.** Clip one vane to a carrier and place track and vane over area to be covered. **Make sure to leave approximately 1/2" clearance at the bottom of the vanes.** Then mark the position of the track.
2. **Second, mark the position of the brackets.** Make a mark 1/4" above the first mark (allowing room for the bracket head) for the brackets (Fig. A). We recommend you use a level for this step.
3. Mount the brackets with screws provided (Fig. B).

outside mount

For outside mount, brackets should be positioned approximately 6" in from each end of the headrail.

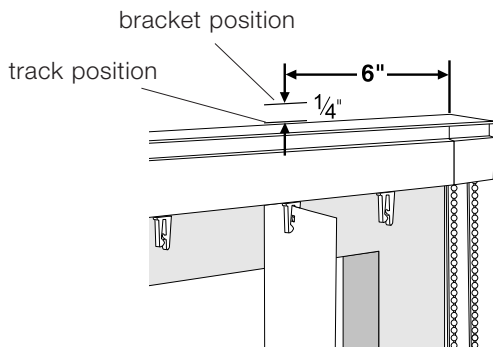

Fig. A

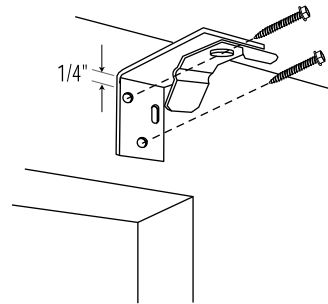

Fig. B

Note: When more than two brackets are supplied, position the additional brackets evenly between the two end brackets.

side mount

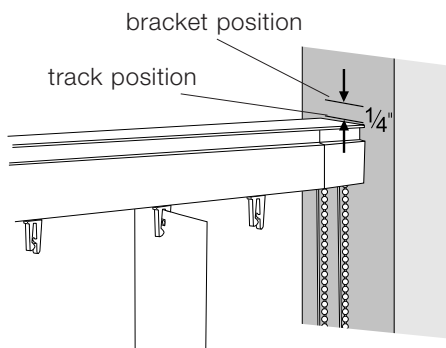

Fig. A

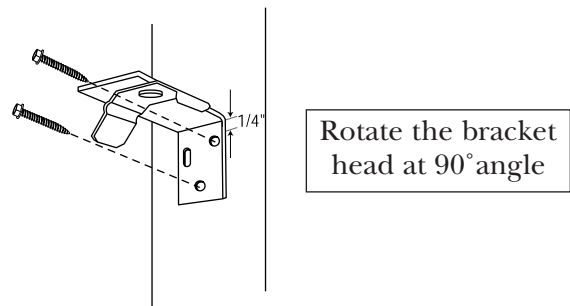
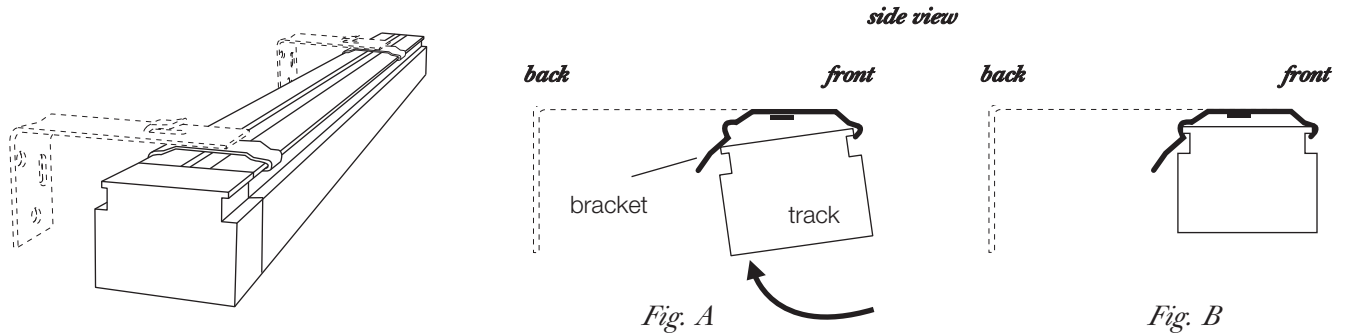

Fig. B

Step 2. Fitting the track into brackets

1. Insert the front part of the bracket inside the top front groove of the track (*Fig. A*).
2. Push the back up so it snaps into the bracket (*Fig. B*).

Note: The track is universal and can be installed with the chain and cord on either left or right.



Step 3. Aligning/realigning the vane carriers

Note: All vertical tracks come with the carriers facing the **correct direction** (long arm facing the chain and cord). Before installing the vanes into the carriers, it is important to make sure the carriers are properly aligned.

1. Pull the chain (or turn the wand) until the carriers stop rotating. The carriers should turn together and face the same direction.
2. If some carriers seem to be misaligned, continue pulling the chain until you hear the cranking sound of the clutch operating. Keep pulling or turning until the misaligned carriers are automatically adjusted.
3. If a carrier is still facing the wrong direction after following 1 and 2, manually (or with pliers if necessary) rotate it back.

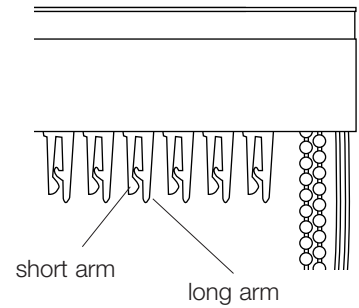

Step 4. Installing the vanes

1. Before installing the vanes, make sure the carriers are positioned as in *Fig. A*.
2. Insert the vanes into the carriers. Make sure all the vanes are facing the same direction (*Fig. B or C*).

Note: vanes could be inserted as illustrated in *Fig. B* or *Fig. C*. Make your choice according to your need for light and privacy.

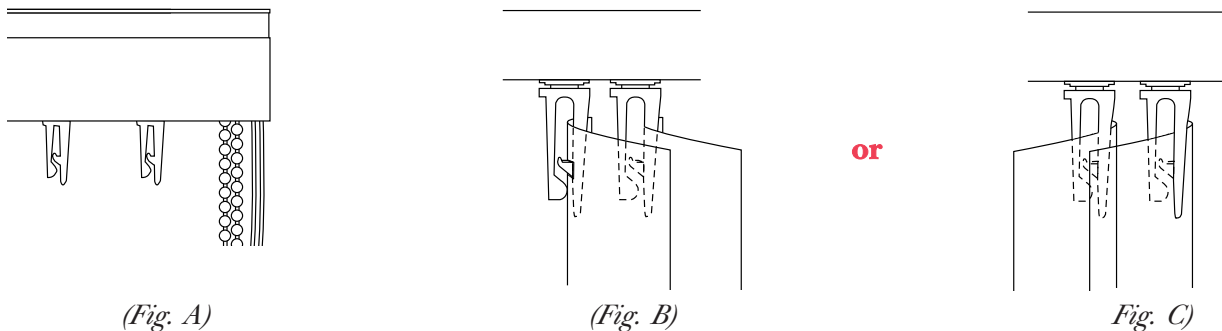

To remove the vanes, first rotate the carriers to the open position as illustrated here. Then slide a card between the vane and carrier clip to open the carrier sufficiently and remove the vane (Fig. D).

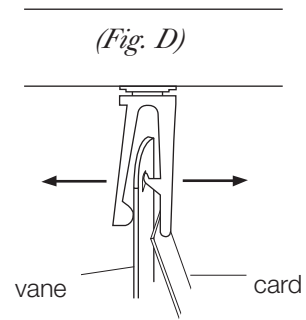

Step 5. Only if you have ordered a valance: Installing the valance

Inside mount

Valance should be mounted with the mounting brackets as illustrated in Fig B on page 5.

Outside mount

Note: To ensure a more secure fit of the valance, the top of the valance can be trimmed down with a utility knife by scoring the back of it and snapping off the excess.

1. Secure the valance clips by snapping them on the track (Fig. A).
2. Slide valance into the lip of the valance clips (Fig. B).

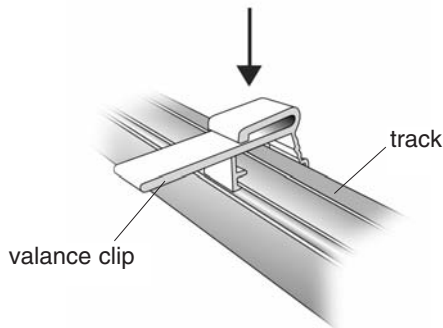

(Fig. A)

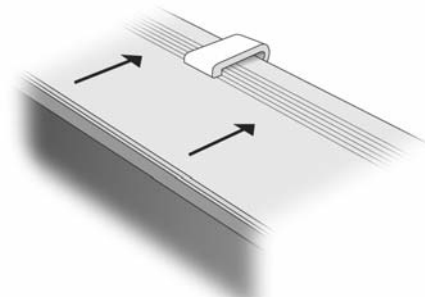

(Fig. B)

Step 6. Mounting the Safety Clutch Device

The Safety Clutch Device can be mounted inside the frame, on the frame or on the wall. First mount the device without the cover (Fig. A). Then install and secure the cover (Fig. B).

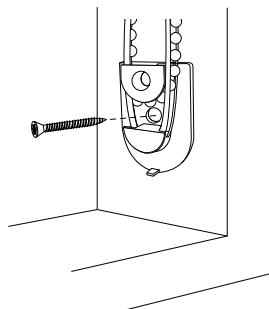

(Fig. A)

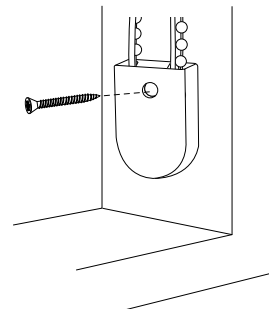

(Fig. B)

UltraTrak™ Advantages

UltraTrak™ is among the most advanced, state-of-the-art vertical blind tracks on the market today. Featuring sturdier, heavy-duty aluminum alloy construction, its ultra-smooth carrier gliding movement requires less pull force than conventional track systems. As well, it features improved clutch alignment, making it easier to realign vanes. These are just a few reasons why we're proud to guarantee this track for life! *See store for complete product warranty details.*

Replacing Carrier Clips

Occasionally an accidental twist or pull, if of great enough force, may break the carrier clip that holds the vertical vanes in place. Should this occur, follow these simple instructions:

1. Remove the plastic horseshoe clip by inserting the tip of a pen, or similar sharp instrument, into the hole and pulling it free.
2. Pull down on the broken clip to free it from the carrier and discard.
3. Insert the new carrier clip (two are supplied with the blind). Note that it is inserted facing the same direction as the other clips.
4. Reinsert the horseshoe clip until it snaps into place, locking the new carrier clip in position.

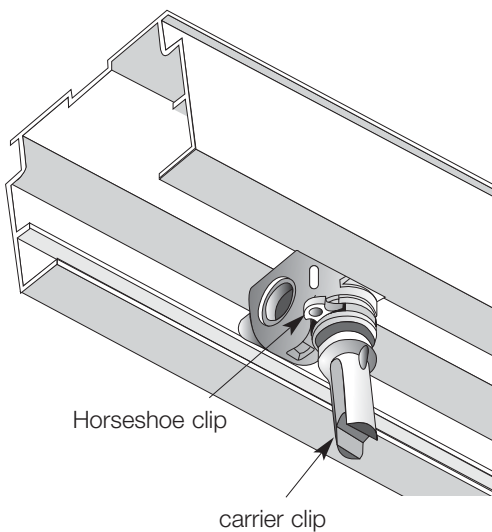

Removal of Old Carrier

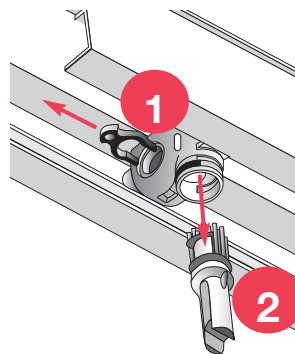

1. Remove the horseshoe clip
2. Remove the broken carrier clip

Installation of New Carrier

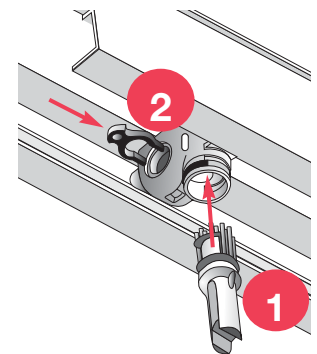

1. Insert the new carrier clip
2. Reinsert the horseshoe clip

Repairing Vanes with VaneSaver Clips

Accidental breakage of the plastic vane tops (plastic above the square slot area) may occasionally occur. For this reason, two free VaneSaver clips have been included in your order. To attach a VaneSaver clip, firmly place the metal clips on each side of the end of the broken vane, until the plastic is fully inserted. The vane is now ready to hang securely.

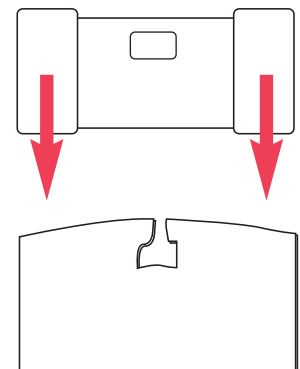

Troubleshooting

The carriers and vanes won't line up.

1. First make sure all the vanes are properly placed on the carriers, facing the same direction.
2. Then refer to Step 4 on page 7 to realign the carriers.

The vanes stick together.

This is caused by static cling. To solve this, wipe the vanes with a damp cloth, or apply anti-static spray that can be purchased off the shelf.